

Glass Worker 625kg Glazing Robot (Model: VHIREGW625)

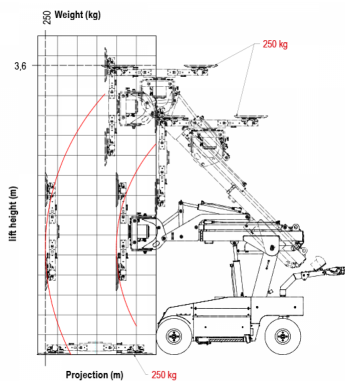
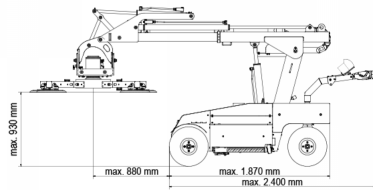

- Load capacity max. 625kg
- Silicone-free suction plates (no marks)
- Additional manual extension (610mm)
- Fully hydraulic extension
- Vertical mounting up to 3.60m
- Overhead mounting up to 4.20m
- Sensitive hydraulics
- Sensitive radio remote control with LCD display, charger, second battery and accessories
- Visual display of all queries in the radio remote control
- Self-monitoring safety system
- Plug&Play delivery
- Overload key
- Hydraulic side shift in vacuum cross (+/-50mm)
- Automatic angle correction
- 6 suction plates d350mm
- Hydraulic turning
- Hydraulic swivelling
- Front drive 3kW
- Operating instructions with CE declaration of conformity
- Own weight approx. 1035-1095kg

Attributes:

Product Code: VHIREGW625

Unit Of Sale: Per Day

