

Kappel Hydraulica DSH2-12V 1200kg Vacuum Lifter (Model: T0037)

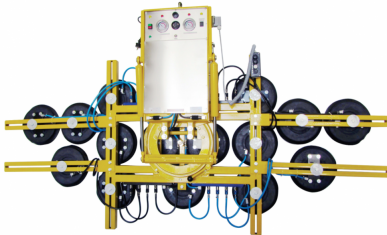

- This lifter is a versatile sixteen pad lifter that comes with two extension arms as standard, increasing capacity to 1200kg and offering additional stabilisation of larger loads.

- It also comes with two hydraulic rams for seamless power tilting and a user-friendly enclosed control panel.

- Glass, metal and non-porous materials can be safely and easily tilted from upright to horizontal position with the Hydraulicas 90° powered tilt function. Manual 135° left and right lockable rotation is also included as standard along with cable remote control.

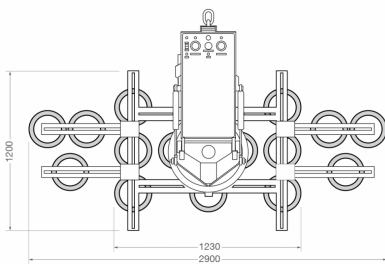

- **Key Features**

- Capacity: 1200kg.
- Manual 135° left & right lockable rotation.
- 12v rechargeable battery with integral 110v or 240v charger and battery energy gauge.
- Two extension arms with variable position pads supplied as standard.
- Audio-visual low vacuum warning.
- Cable remote control as standard.

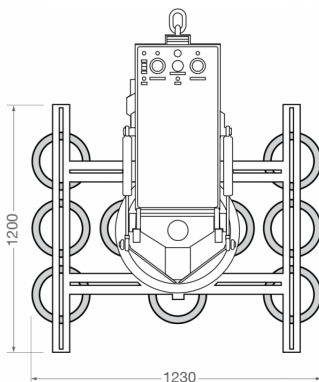

Attributes:

Product Code: T0037
Unit Of Sale: Each

