

1. Base Rail

The Crystal View base channel should be placed onto its designated position and the holes marked onto the substrate for drilling. Once the shoe is lined up with the holes and is level, the fixings should be tightened up to make the channel rigid. The fixings must be tightened in accordance with the bolt manufacturer's instructions. M12 bolts/fixings must be used. The dowels should be used to align the channels and an inhibitor or clear sealant (Neutral Cure/low-modulus silicone) rubbed on the raw aluminium when the channels are butted together. This should be wiped clear on the channel surface. Ensure the channel is clean inside before fitting the glass. If cutting the channel make sure all metal filings (swarf) are removed.

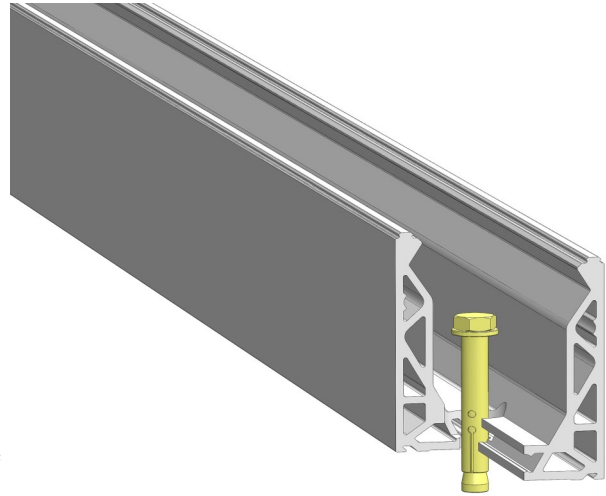

When fitting to metalwork a barrier between different metal types must be used
Additional waterproofing may be required.

We strongly advise measuring and ordering the glass after installation of the channel. Gaps between the glass should be no less than 5mm

In extreme temperature changes the profiles may expand and contract. Small gaps may need to be left between profiles.

2. Glass Slip Clamp Fitting

The glass slip clamps need to be placed onto the bottom of the glass. This requires lifting the glass off the floor sufficiently and pushing into place or applying the clamps to the bottom of the glass. The slip clamps require even spacing. When 4 clamps are used on a metre wide panel the clamps need to be positioned 125mm in from the edge of the glass and then at 250mm centres. When using 3 clamps per metre (12 + 13.5mm glass) the spacing needs to be 200mm from the end and then 300mm centres. The glass can now be lowered into the channel.

You must check to ensure 3 or 4 clamps per metre can be used.

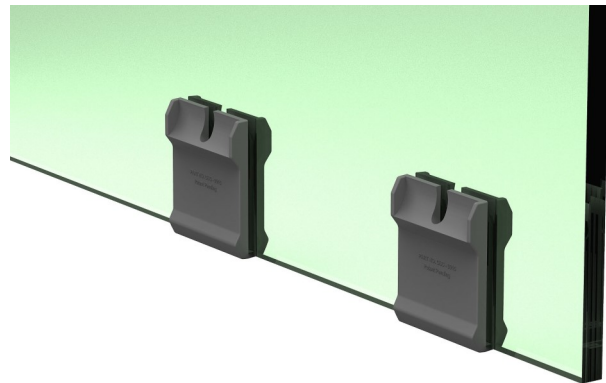

3. Glass Clamp Bar Fitting

Once the glass is in the channel the clamp bars must be positioned into the top of each glass slip clamp. Screw the bolt into the flat side as the shaped side of the bar will sit nearest to the glass. Each clamp bar can now be inserted into the glass slip clamps. As shown in the image to the right.

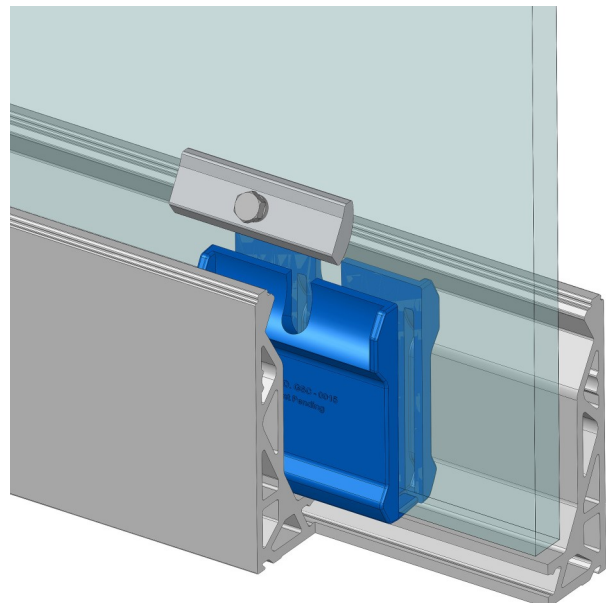

4. Getting Glass Level and Tightening Bolts

The bolts now need tightening against the channel to get the glass in the desired position. To adjust the glass into position the bolts need to be unscrewed back towards the wall of the channel. Start by getting the outer clamps tightened before tightening the bolts on the middle clamps. Both sides need to be tightened to make sure the glass is fixed into place. Give the bolts an additional half turn from their tight position to ensure that the glass is securely held in place. A torque of 8nm should be applied. An adhesive, such as Loctite, should be used on the threads once the glass is set.

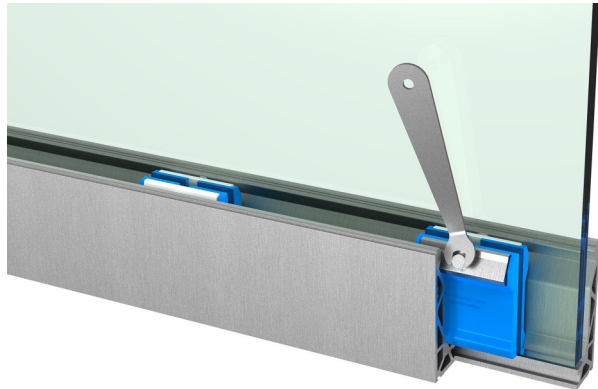

5. Finishing Touches

Beads

The gasket requires feeding into rebates on the smaller profiles, do not stretch the gasket. Once the gasket is flush with each end of the strip it can now be cut and clipped onto the top of the channel. This can be done by pressing firmly down on the profile working from one end to the other. A soft mallet may be required.

End Caps

There are 2 versions of end caps. A Knock-in and flat plate. Both require adhering to the channel end. To keep water from submerging the glass we suggest drilling the thin end caps below the glass line with a min. 8mm hole or we can supply slotted versions. Other draining methods may need to be considered depending on the size of the balustrade and design.

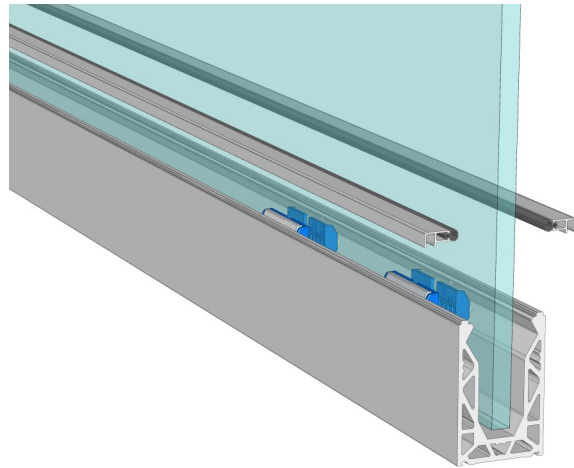

6. Cleaning

Once everything is correctly in place and the job is complete, the glass and channel need to be cleaned. Use a non-abrasive glass cleaner on the glass and warm soapy water on the Crystal View channel. We also recommend a soft sponge or cloth, again to avoid any risk of scratching. Please refer to the Operating and Maintenance manual for further maintenance instructions.